

**PACKAGING ITEMS:**  
(ITEMS SHIPPED SEPERATE)

**QTY -1**

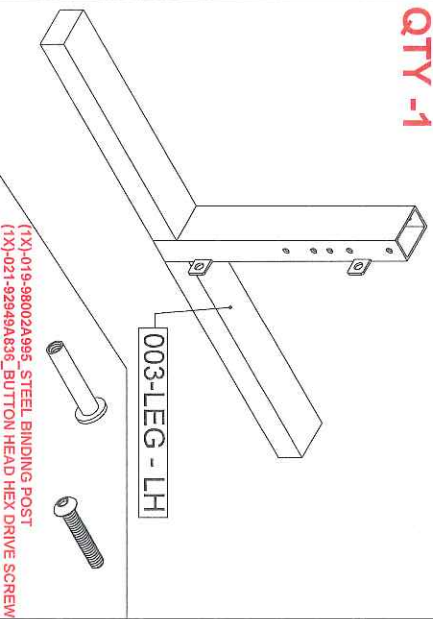

**BAGGED TOGETHER:**  
(2X) LOCKING CASTERS  
(2X) NON LOCKING CASTERS  
(16x) SCREWS - M6 - 92000A426

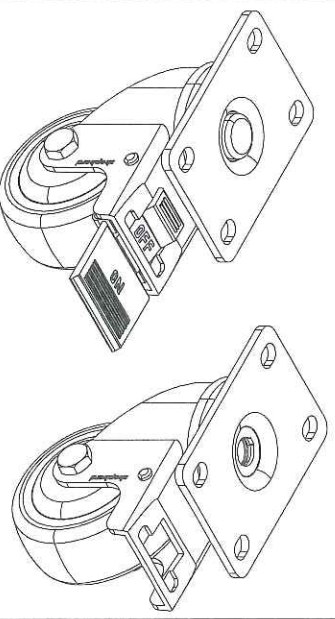

**QTY -1**

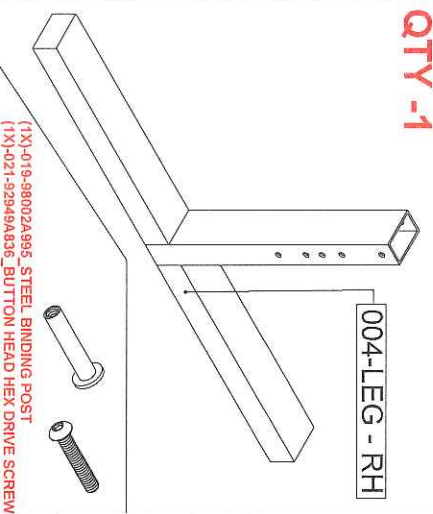

**QTY - (1)**  
**PRE-ASSEMBLED UNIT**

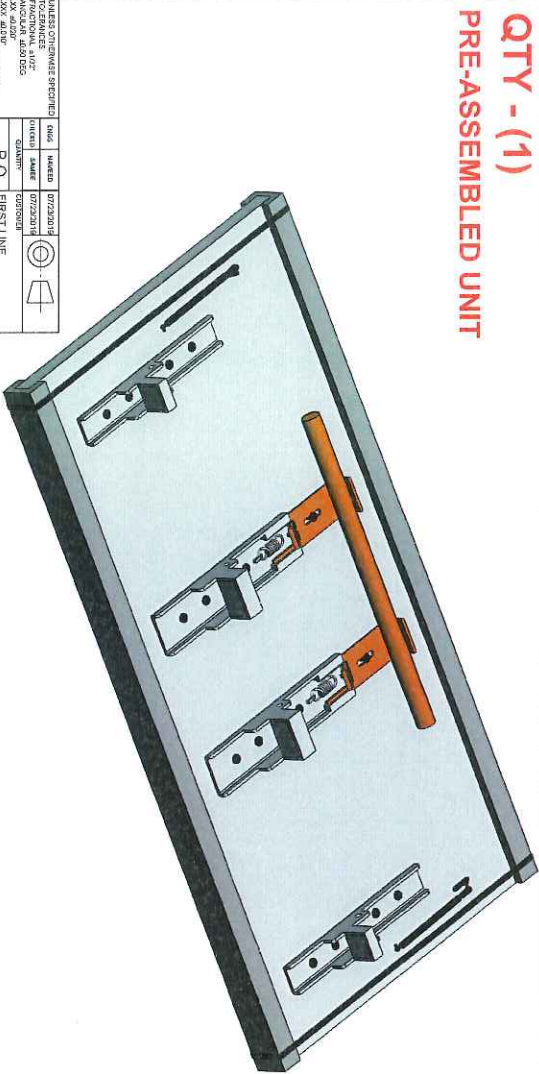

APPROVAL:   
SIGNATURE:   
DATE: 01/21/15  
GRAIN DIRECTION  
WHERE APPLICABLE

UNLESS OTHERWISE SPECIFIED  
DIMENSIONS ARE IN INCHES  
TOLERANCES UNLESS OTHERWISE SPECIFIED  
FRACTIONAL DECIMAL ANGLES  
X.XX .0005  
X.X .001  
X .005  
DO NOT SCALE DRAWINGS

REV	DATE	DESCRIPTION
001	07/23/2014	ISSUE FOR PRODUCTION
002	07/23/2014	ISSUE FOR PRODUCTION
003	07/23/2014	ISSUE FOR PRODUCTION
004	07/23/2014	ISSUE FOR PRODUCTION
005	07/23/2014	ISSUE FOR PRODUCTION
006	07/23/2014	ISSUE FOR PRODUCTION
007	07/23/2014	ISSUE FOR PRODUCTION
008	07/23/2014	ISSUE FOR PRODUCTION
009	07/23/2014	ISSUE FOR PRODUCTION
010	07/23/2014	ISSUE FOR PRODUCTION

DESIGNED BY: P.O.  
CHECKED BY: P.O.  
DRAWN BY: P.O.  
FIRST LINE

MATERIAL SPECIFICATIONS

PLEASE SIGN AND RETURN  
A SIGNATURE ON THIS DRAWING  
INDICATES THAT ALL DETAILS AND  
FINISHES ARE TO CLIENTS SPECIFICATIONS  
AND ARE APPROVED FOR MANUFACTURING  
CHANGES MADE AFTER SIGNED APPROVAL  
OF THIS DRAWING WILL BE AT THE BUYER'S  
RISK AND MAY RESULT IN ADDITIONAL COSTS AND WILL  
EXTEND LEAD TIME

**ADVISORY:**  
LAMINATE CAN BE DAMAGED UNDER  
INAPPROPRIATE USE SUCH AS ACCIDENTS,  
ABUSE OR MISUSE, ACTS OF NATURE,  
EXPOSURE TO EXTREME TEMPERATURE,  
MOISTURE DAMAGE,  
DAMAGE FROM ABRASIVE CLEANERS OR  
HARSH CHEMICALS OR  
IMPROPER MAINTENANCE OR REPAIR.  
ALL DAMAGED PRODUCTS MUST BE  
REMOVED WITHIN 24 HRS AFTER  
RECEIVING OR WILL CALL  
CUSTOMER TO VIEW UNIT IN OUR SHOP  
BEFORE  
WILL CALL OR INSTALL

**PROPRIETARY AND CONFIDENTIAL**  
THE INFORMATION CONTAINED IN THIS  
DRAWING IS THE SOLE PROPERTY OF  
VALENTINE WOODWORKS, A DIVISION  
OF VALENTINE INDUSTRIES, A WHOLE  
SALE COMPANY. NO PART OF THIS  
DRAWING IS TO BE REPRODUCED OR  
TRANSMITTED IN ANY FORM OR BY  
ANY MEANS, WITHOUT THE WRITTEN PERMISSION OF  
VALENTINE WOODWORKS IS  
FORBIDDEN.

**VALENTINE**  
WOODWORKS  
3281 HUNDE AVENUE  
MILWAUKEE, WI 53211-1894  
TEL: 774.901.1788  
FAX: 774.901.1789

**BALLISTIC TABLE** REV -  
DWG. NAME: SHIPPING INSTRUCTIONS  
PRODUCTION DRAWING SHEET 21 OF X

**PACKAGING ITEMS:**  
**(ITEMS SHIPPED SEPERATE)**

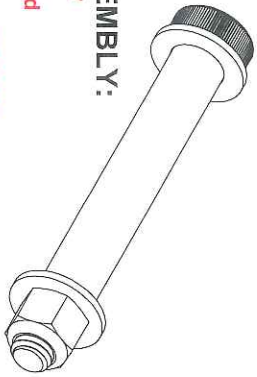

**3" LOCK SCREW ASSEMBLY:**

- (2x) - 90298A724 - 1/2" Shoulder Diameter, 3" Shoulder Length, 3/8"-16 Thread
- (4x) - 93286A049 - 1/2" Screw Size, 0.515" ID, 0.875" OD
- (2X) - 95615A140 - Medium-Strength Steel Nylon-Insert Locknut Grade 5, Zinc-Plated, 3/8"-16 Thread Size

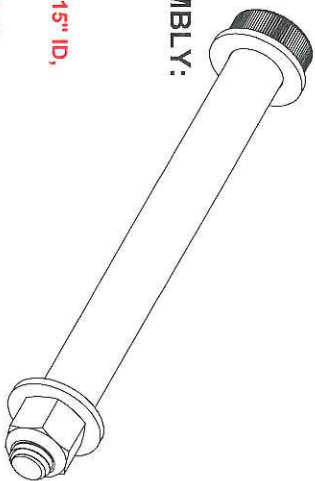

**4.25" LOCK SCREW ASSEMBLY:**

- (2x) - 90298A729 - 1/2" Shoulder Diameter, 4.25" Shoulder Length, 3/8"-16 Thread
- (4x) - 93286A049 - 1/2" Screw Size, 0.515" ID, 0.875" OD
- (2X) - 95615A140 - Medium-Strength Steel Nylon-Insert Locknut Grade 5, Zinc-Plated, 3/8"-16 Thread Size

**QTY - (1)**

005-CENTER U BRACKET

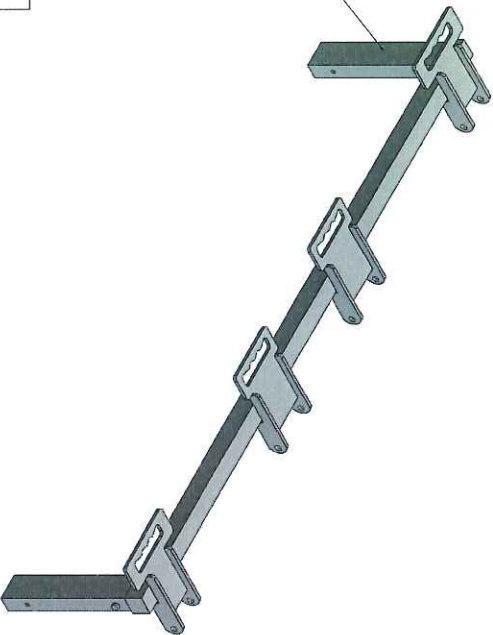

MATERIAL SPECIFICATIONS

PLEASE SIGN AND RETURN A SIGNATURE ON THIS DRAWING INDICATES THAT ALL DETAILS AND FINISHES ARE TO CLIENT'S SPECIFICATIONS AND ARE APPROVED FOR MANUFACTURING CHANGES MADE AFTER SIGNED APPROVAL. DRAWING AND PARTS LISTING WILL REMAIN VALID UNLESS OTHERWISE NOTIFIED. ANY RESULT IN ADDITIONAL COSTS AND WILL EXTEND LEAD TIME

**ADVISORY**

LAMINATE CAN BE DAMAGED UNDER INAPPROPRIATE USE SUCH AS ACCIDENTS, ABUSE OR MISUSE, ACTS OF NATURE, EXPOSURE TO EXTREME TEMPERATURE, MOISTURE DAMAGE, DAMAGE FROM ABRASIVE CLEANERS OR HARSH CHEMICALS, OR IMPROPER MAINTENANCE OR REPAIR. ALL DAMAGED PRODUCTS MUST BE REPORTED WITHIN 24 HRS AFTER RECEIVING OR WILL CALL CUSTOMER TO VIEW UNIT IN OUR SHOP BEFORE

WILL CALL OR INSTALL

**PROPRIETARY AND CONFIDENTIAL**

THE INFORMATION CONTAINED IN THIS DRAWING IS THE SOLE PROPERTY OF BALLISTIC TABLE AND IS TO BE USED ONLY FOR THE REPRODUCTION IN PART OR AS A WHOLE WITHOUT THE WRITTEN PERMISSION OF VALENTINE WOODWORKS INC.



VALENTINE

WOODWORKS

INC.

2701 HUNTERS AVE.

WILSON, KY 40391-1884

TEL: 502-338-1188

FAX: 502-338-1188

WWW.VALENTINEWOODWORKS.COM

REV -

BALLISTIC TABLE

DWG. NAME: SHIPPING INSTRUCTIONS

PRODUCTION DRAWING

SHEET 21 OF 2

APPROVAL: *[Signature]* DATE: *8/21/19*

GRAIN DIRECTION: *[Arrow pointing right]* WHERE APPLICABLE

TOLERANCES: UNLESS OTHERWISE SPECIFIED

FINISH	WELD	HAZARD	PROTECTIVE
AS SHOWN	AS SHOWN	AS SHOWN	AS SHOWN
UNLESS OTHERWISE SPECIFIED	UNLESS OTHERWISE SPECIFIED	UNLESS OTHERWISE SPECIFIED	UNLESS OTHERWISE SPECIFIED

P.O. FIRST LINE

# ASSEMBLY INSTRUCTIONS:

**STEP 1: LAY TABLETOP ON THE FLOOR WITH HARDWARE FACING UP. LEAVE CORNER PROTECTOR AND NYLON STRAPS ATTACHED UNTIL THE TABLE IS FULLY ASSEMBLED AND STANDING UPRIGHT**

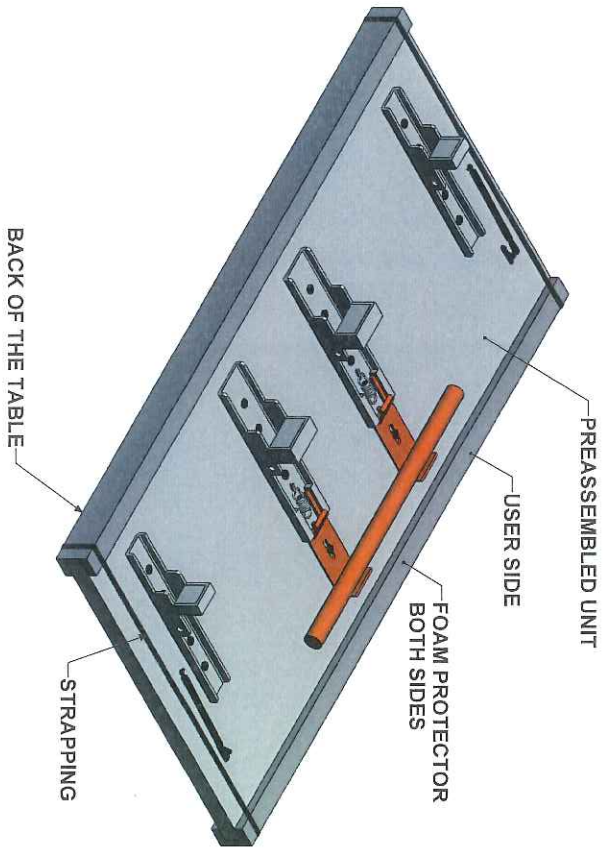

**NOTE: DO NOT REMOVE THE STRAPPING AND FOAM PROTECTORS UNTIL THE TABLE IS FULLY ASSEMBLED**

APPROVAL: *[Signature]* DATE: *8/5/19*

SIGNATURE: *[Signature]*

GRAIN DIRECTION:  GRAIN DIRECTION WHERE APPLICABLE

FINISHES:  FINISHES AS SPECIFIED  FINISHES AS NOTED ON DRAWING

QTY	UNIT	DATE	BY
1	TABLE	07/22/2019	[Signature]
1	TABLE	07/22/2019	[Signature]

P.O. FIRST LINE

**STEP 2: INSTALL THE CENTER U BRACKET SO THAT IT IS VERTICAL. CONNECT THE OTHER END OF THE STRUT ASSEMBLY TO THE U BRACKET.**

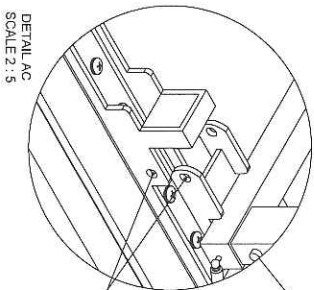
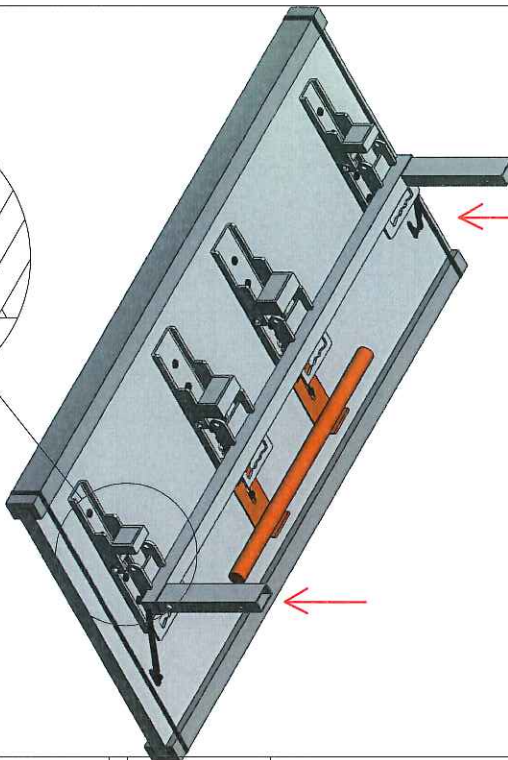

**MATCH THESE HOLES TOGETHER AND INSTALL THE LOCKING BOLTS**

MATERIAL SPECIFICATIONS

PLEASE SIGN AND RETURN A SIGNATURE WHICH INDICATES THAT ALL DETAILS AND FINISHES ARE TO CLIENT'S SPECIFICATIONS AND ARE APPROVED FOR MANUFACTURING CHANGES MADE AFTER SIGNED APPROVAL DRAWINGS IS RECEIVED BY VALENTINE. MANY CHANGES ARE MADE AND WILL EXTEND LEAD TIME

**ADVISORY**

LAMINATE CAN BE DAMAGED UNDER INAPPROPRIATE USE SUCH AS ACCIDENTS, ABUSE OR MISUSE, ACTS OF NATURE, EXPOSURE TO EXTREME TEMPERATURE, MOISTURE DAMAGE, DAMAGE FROM ABRASIVE CLEANERS OR HARSH CHEMICALS OR IMPROPER MAINTENANCE OR REPAIR. ALL DAMAGED PRODUCTS MUST BE REPORTED WITHIN 24 HRS AFTER RECEIVING OR WILL CALL CUSTOMER TO VIEW UNIT IN OUR SHOP BEFORE

WILL CALL OR INSTALL

**PROPRIETARY AND CONFIDENTIAL**

THE INFORMATION CONTAINED IN THIS DRAWING IS THE SOLE PROPERTY OF VALENTINE. IT IS TO BE USED ONLY FOR THE PROJECT AND FOR THE CLIENT'S USE. REPRODUCTION OR TRANSMISSION OF THIS DRAWING IN ANY MANNER WITHOUT THE WRITTEN PERMISSION OF VALENTINE WOODWORKS IS PROHIBITED.

**VALENTINE**

2341 HOBBS AVE. # 9  
MILWAUKEE, WI 53216  
TEL: 774.801.1124

BAULISTIC TABLE REV -

DWG. NAME: ASSEMBLY INSTRUCTIONS

PRODUCTION DRAWINGS SHEET 18 OF X



# ASSEMBLY INSTRUCTIONS:

STEP 2: CONTINUED...

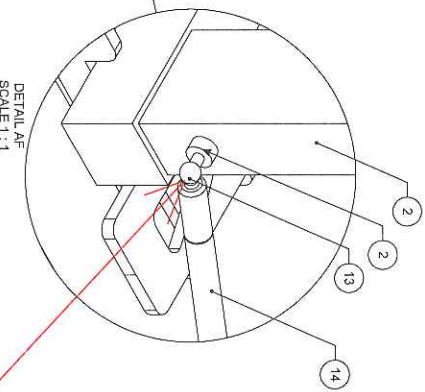

**SNAP THIS END OF THE STRUT INTO THE BALL JOINT OF THE LEG**

**\*NOTE:  
DO NOT REMOVE THE STRAPPING AND FOAM PROTECTORS UNTIL THE TABLE IS FULLY ASSEMBLED**

APPROVAL: \_\_\_\_\_ SIGNATURE: *[Signature]* DATE: 8/21/19

GRAIN DIRECTION: \_\_\_\_\_ YES/NO AVAILABLE: \_\_\_\_\_

TOLERANCES UNLESS OTHERWISE SPECIFIED: FINISH: \_\_\_\_\_

DESCRIPTION	QTY	UNIT
TABLE	1	TABLE

P.O. \_\_\_\_\_ FIRST LINE \_\_\_\_\_

MATERIAL SPECIFICATIONS

PLEASE SIGN AND RETURN. A SIGNATURE FROM ALL THE PARTS AND FINISHES ARE TO CLIENT'S SPECIFICATIONS AND ARE APPROVED FOR MANUFACTURING CHANGES MADE AFTER SIGNED APPROVAL. DRAWINGS IS RECEIVED BY VALENTINE, MAY RESULT IN EXTEND LEAD TIME

**ADVISORY**

LAMINATE CAN BE DAMAGED UNDER IMPROPER USE. AVOID EXCESSIVE WEIGHTS, ABUSE OR MISUSE. ACTS OF NATURE, EXPOSURE TO EXTREME TEMPERATURE, MOISTURE DAMAGE, DAMAGE FROM ABRASIVE CLEANERS OR HARSH CHEMICALS OR IMPROPER MAINTENANCE OR REPAIR.

ALL DAMAGED PRODUCTS MUST BE REPORTED WITHIN 24 HRS AFTER RECEIVING OR WILL CALL CUSTOMER TO VIEW UNIT IN OUR SHOP BEFORE WILL CALL OR INSTALL.

**PROPRIETARY AND CONFIDENTIAL**

THE INFORMATION CONTAINED IN THIS DRAWING IS THE SOLE PROPERTY OF VALENTINE WOODWORKS. ANY REPRODUCTION OR TRANSMISSION OF THIS DRAWING WITHOUT THE WRITTEN PERMISSION OF VALENTINE WOODWORKS IS PROHIBITED.



2701 HOBBS AVE. S. SUITE 100  
 FALLS CHURCH, VA 22034  
 TEL: 703.441.1126  
 FAX: 703.441.1126

**VALENTINE**

W O O D W O R K S

BALLISTIC TABLE REV -

DWG. NAME: ASSEMBLY INSTRUCTIONS

PRODUCTION DRAWING SHEET 38 OF X

# ASSEMBLY INSTRUCTIONS:

STEP 3: DETERMINE THE DESIRED HEIGHT OF TABLE AND ATTACH LEFT HAND & RIGHT HAND LEGS AT DESIRED HEIGHT (SEE HEIGHT CHART)

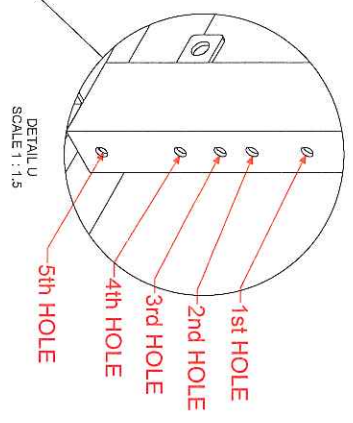
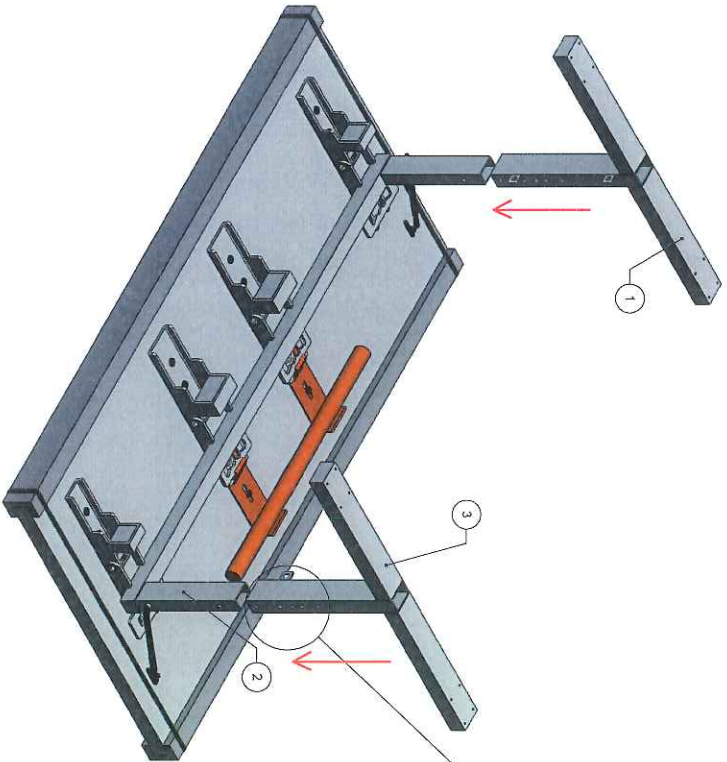

HEIGHT CHART	ADJUSTABLE HEIGHT	OVERALL HEIGHT FROM GROUND TO TOP
1st HOLE		25"
2nd HOLE		26.75"
3rd HOLE		27.75"
4rd HOLE		29"
5th HOLE		31.5"

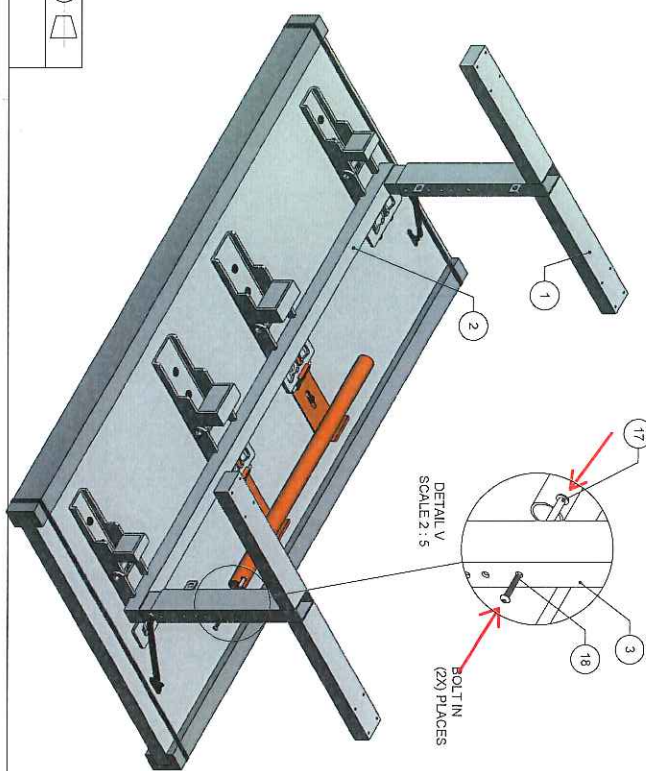

## MATERIAL SPECIFICATIONS

PLEASE SIGN AND RETURN A SHOP DRAWING INDICATES THAT ALL DETAILS AND FINISHES ARE TO CLIENT'S SPECIFICATIONS AND ARE APPROVED FOR MANUFACTURING CHANGES MADE AFTER SIGNED APPROVAL. DRAWINGS RECEIVED BY VALENTINE, MAY BE MODIFIED FOR MANUFACTURING AND WILL RESULT IN EXTENDED LEAD TIME.

**ADVISORY**  
 LAMINATE CAN BE DAMAGED UNDER IMPACT, OVERHEATING, STAINING, ABUSE OR MISUSE, ACTS OF NATURE, EXPOSURE TO EXTREME TEMPERATURE, MOISTURE DAMAGE, DAMAGE FROM ABRASIVE CLEANERS OR HARSH CHEMICALS, OR IMPROPER MAINTENANCE OR REPAIR. ALL DAMAGED PRODUCTS MUST BE REPORTED WITHIN 24 HRS AFTER RECEIVING OR WILL CALL CUSTOMER TO VIEW UNIT IN OUR SHOP BEFORE  
 WILL CALL OR INSTALL

**PROPRIETARY AND CONFIDENTIAL**  
 THE INFORMATION CONTAINED IN THIS DRAWING IS THE SOLE PROPERTY OF VALENTINE WOODWORKS, ANY REPRODUCTION OR TRANSMISSION WITHOUT THE WRITTEN PERMISSION OF VALENTINE WOODWORKS IS PROHIBITED.

**VALENTINE**  
 WOODWORKS  
 2561 HOBBS AVE  
 FULLERTON, CA 92633  
 TEL: 714.801.1124  
 FAX: 714.801.1126

**BALLISTIC TABLE** REV -  
 DWG. NAME: ASSEMBLY INSTRUCTIONS  
 PRODUCTION DRAWING SHEET 19 OF X

APPROVAL: *[Signature]* DATE: *8/3/19*

GRAIN DIRECTION: *[Arrow pointing right]*

TOLERANCES: FINISHES: PROTECTIVE COATINGS: CO NOT SCALE DRAWING

QTY	UNIT	DESCRIPTION
1	TABLE	TABLE
1	LEG	LEG
1	BRACKET	BRACKET
1	BOLT	BOLT

P.O. FIRST LINE

# ASSEMBLY INSTRUCTIONS:

STEP 4: INSTALL THE MODESTY PANEL WITH (4) SCREWS THROUGH THE HOLES, INSIDE THE LEFT AND RIGHT LEG, MAKING SURE THE ORANGE EDGE FACES DOWN:

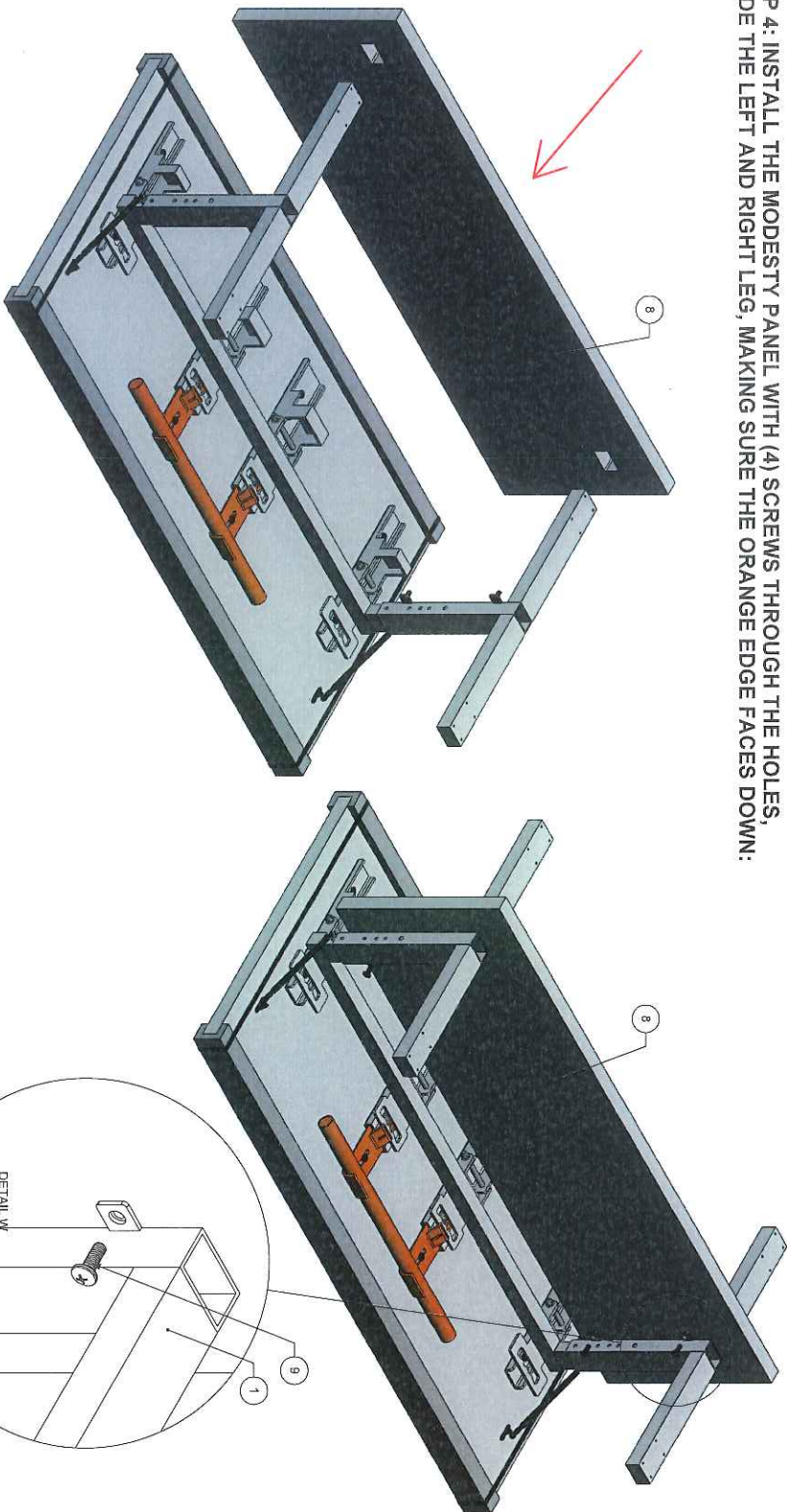

MATERIAL SPECIFICATIONS

PLEASE SIGN AND RETURN A SIGNATURE TO THE REPAIRING FINISHERS TO CLIENT'S SPECIFICATIONS AND ARE APPROVED FOR MANUFACTURING CHANGES MADE AFTER SIGNED APPROVAL. DAMAGE TO THE PRODUCT, INCLUDING ANY ADDITIONAL COSTS, AND WILL BE THE CUSTOMER'S RESPONSIBILITY AND WILL EXTEND LEAD TIME.

**ADVISORY**

LAMINATE CAN BE DAMAGED UNDER INAPPROPRIATE USE SUCH AS ACCIDENTS, ABUSE OR MISUSE, ACTS OF NATURE, EXPOSURE TO EXTREME TEMPERATURE, MOISTURE DAMAGE, DAMAGE FROM ABRASIVE CLEANERS OR IMPROPER MAINTENANCE OR REPAIR. ALL DAMAGED PRODUCTS MUST BE REPAIRED WITHIN 24 HRS AFTER RECEIVING OR WILL CALL. CUSTOMER TO VIEW UNIT IN OUR SHOP BEFORE REPAIR.

**PROPRIETARY AND CONFIDENTIAL**

THE INFORMATION CONTAINED IN THIS DRAWING IS THE SOLE PROPERTY OF VALENTINE. IT IS TO BE USED ONLY FOR THE REPAIR OF THE PRODUCT AS SHOWN AND WITHOUT THE WRITTEN PERMISSION OF VALENTINE. REPRODUCTION OF THIS DRAWING IS PROHIBITED.



2250 HERRICK AVE. W. O. D. N. S. 71-48011284  
 BALLISTIC TABLE REV -  
 DWG. NAME: ASSEMBLY INSTRUCTIONS  
 PRODUCTION DRAWING SHEET 20 OF X

APPROVAL: *[Signature]* DATE: 8/2/19

GRAIN DIRECTION: *[Arrow pointing right]*

TOLERANCES: DIMENSIONS UNLESS OTHERWISE SPECIFIED

UNIT	SCALE	DATE	BY	REV
INCHES	1:1	8/2/19	[Signature]	1

P.O. FIRST LINE

# ASSEMBLY INSTRUCTIONS:

STEP 5: ROTATE THE TABLE SIDEWAYS AND INSTALL CASTERS WITH (2) NON LOCKING CASTERS ON THE FRONT SIDE OF THE TABLE AND (2) LOCKING CASTERS ON THE USER SIDE OF THE TABLE.

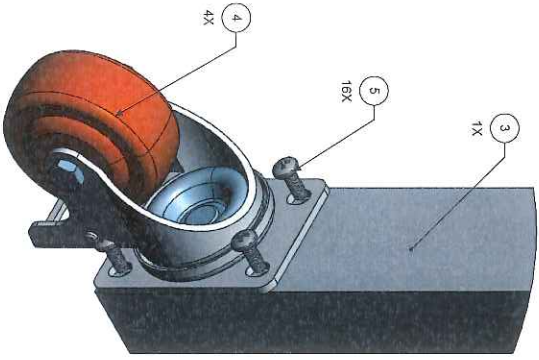

DETAIL AG  
SCALE 1 : 1

LOCKING  
CASTERS  
ON FRONT  
SIDE OF THE TABLE

NON-LOCKING  
CASTERS ON BACK  
SIDE OF THE TABLE

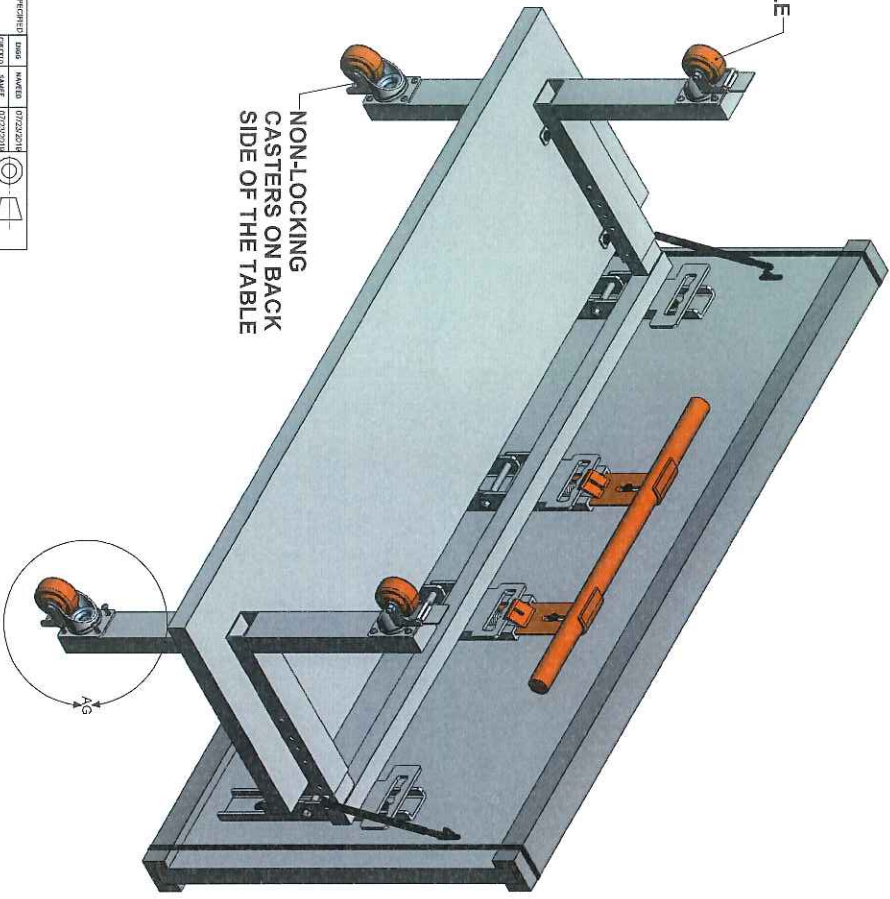

MATERIAL SPECIFICATIONS

PLEASE SIGN AND RETURN  
A SIGNATURE ON THIS DRAWING  
INDICATES THAT ALL DETAILS AND  
FINISHES ARE TO CLIENT'S SPECIFICATIONS  
AND ARE APPROVED FOR MANUFACTURING  
CHANGES MADE AFTER SIGNED APPROVAL  
WILL BE AT THE USER'S RISK AND WILL  
RESULT IN ADDITIONAL COSTS AND WILL  
EXTEND LEAD TIME

**ADVISORY**

LAMINATE CAN BE DAMAGED UNDER  
INAPPROPRIATE USE SUCH AS ACCIDENT'S,  
ABUSE OR MISUSE, ACTS OF NATURE,  
EXPOSURE TO EXTREME TEMPERATURE,  
MOISTURE DAMAGE,  
DAMAGE FROM ABRASIVE CLEANERS OR  
IMPROPER MAINTENANCE/REPAIR.  
ALL DAMAGED PRODUCTS MUST BE  
REMOVED WITHIN 24 HRS AFTER  
RECEIVING OR WILL CALL  
CUSTOMER TO VIEW UNIT IN OUR SHOP  
BEFORE  
WILL CALL OR INSTALL.

**PROPRIETARY AND CONFIDENTIAL**

THE INFORMATION CONTAINED IN THIS  
DRAWING IS THE SOLE PROPERTY OF  
VALENTINE AND IS TO BE KEPT  
CONFIDENTIAL. ANY REPRODUCTION,  
REPRODUCTION IN PART OR AS A WHOLE  
WITHOUT THE WRITTEN PERMISSION OF  
VALENTINE IS PROHIBITED.



2501 HOBBS AVE. TEL: 714-961-1284  
DALLAS, TEXAS 75243 FAX: 714-961-1188  
WWW.VALENTINE.COM  
BOLLTIC TABLE REV -  
DWG. NAME: ASSEMBLY INSTRUCTIONS  
PRODUCTION DRAWING SHEET 20 OF 2

APPROVAL: *[Signature]* DATE: *8/2/19*

GRAIN DIRECTION: *[Arrow pointing right]*

WHERE APPLICABLE: *[Arrow pointing right]*

UNIT SIZE DIMENSIONS SPECIFICATIONS: *[Arrow pointing right]*

CHARACTERISTICS: *[Arrow pointing right]*

FINISHES: *[Arrow pointing right]*

MANUFACTURING TOLERANCES: *[Arrow pointing right]*

ASSEMBLY: *[Arrow pointing right]*

SCALE: *[Arrow pointing right]*

REV	DATE	DESCRIPTION
1	08/02/2019	ISSUE FOR PRODUCTION

DESIGNED BY: *[Signature]* CHECKED BY: *[Signature]*

DATE: *8/2/19* P.O. NO.: *[Blank]*

FIRST LINE: *[Blank]*





# ASSEMBLY INSTRUCTIONS:

THESE TABLES CAN ALSO BE INTERLINKED WITH EACH OTHER AS SHOWN BELOW:

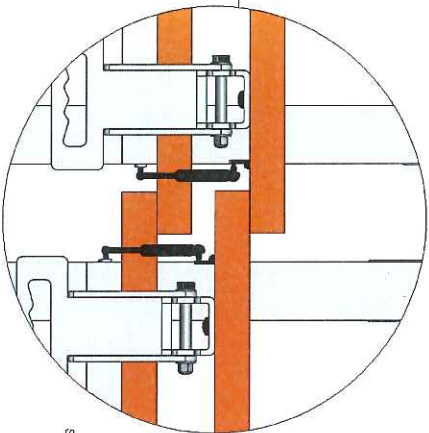
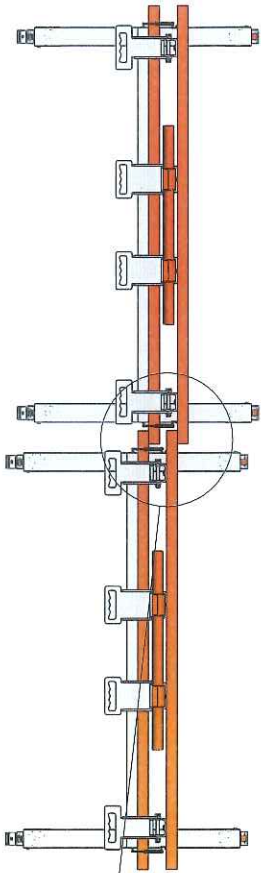
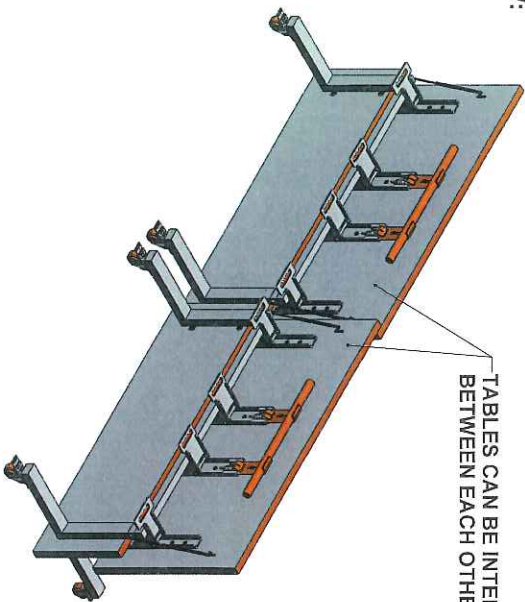
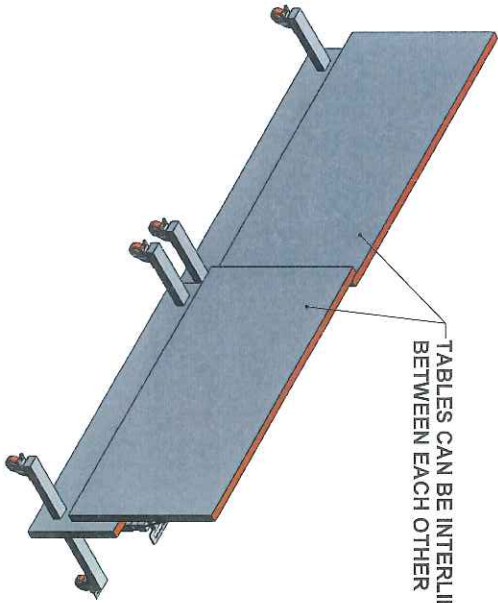

DETAIL AH  
SCALE 1 : 2.5

APPROVAL: \_\_\_\_\_  
SIGNATURE: *[Signature]* DATE: *2/21/19*

GRAIN DIRECTION: *[Arrow pointing right]*  
VALENTINE APPROVED: *[Checkmark]*

TABLES TO BE APPROVED OR CHANGED: \_\_\_\_\_  
TOLERANCES: DIMENSIONS IN PARENTS OR DECIMALS: \_\_\_\_\_  
DIMENSIONS IN PARENTS OR DECIMALS: \_\_\_\_\_  
DIMENSIONS IN PARENTS OR DECIMALS: \_\_\_\_\_  
DIMENSIONS IN PARENTS OR DECIMALS: \_\_\_\_\_

QTY	NAME	DESCRIPTION	DATE	BY
1	P.O.	FIRST LINE		

MATERIAL SPECIFICATIONS

PLEASE SIGN AND RETURN  
A DRAWING OF THIS DRAWING  
INDICATING THE ALTIMETRY AND  
FINISHES ARE TO CLIENTS SPECIFICATIONS  
AND ARE APPROVED FOR MANUFACTURING  
CHANGES MADE AFTER SIGNED APPROVAL  
RESULT IN COSTS AND WILL  
EXTEND LEAD TIME

**ADVISORY**

LAMINATE CAN BE DAMAGED UNDER  
IMPACTION OR CONTACT WITH SHARP ACCIDENTS,  
ABUSE OR MISUSE SUCH AS ACCIDENTS,  
EXPOSURE TO EXTREME TEMPERATURE,  
MOISTURE DAMAGE,  
DAMAGE FROM ABRASIVE CLEANERS OR  
HARSH CHEMICALS OR  
IMPROPER MAINTENANCE OR REPAIR.  
ALL DAMAGED PRODUCTS MUST BE  
REPORTED WITHIN 24 HRS AFTER  
RECEIVING OR WILL CALL  
CUSTOMER TO VIEW UNIT IN OUR SHOP  
BEFORE  
WILL CALL OR INSTALL

**PROPRIETARY AND CONFIDENTIAL**

THE INFORMATION CONTAINED IN THIS  
DRAWING IS THE SOLE PROPERTY OF  
VALENTINE WOODWORKS. ANY  
REPRODUCTION OR TRANSMISSION OF  
THIS INFORMATION IN ANY FORM OR BY  
ANY MEANS WITHOUT THE WRITTEN PERMISSION OF  
VALENTINE WOODWORKS IS  
PROHIBITED.



VAL WOODWORKS  
3700 LINDSEY AVE SEASD  
FULLERTON, CA 92833  
TEL: 714-201-1188

BALLISTIC TABLE REV -

DWG. NAME: ASSEMBLY INSTRUCTIONS

PRODUCTION DRAWING SHEET 20 OF 2